

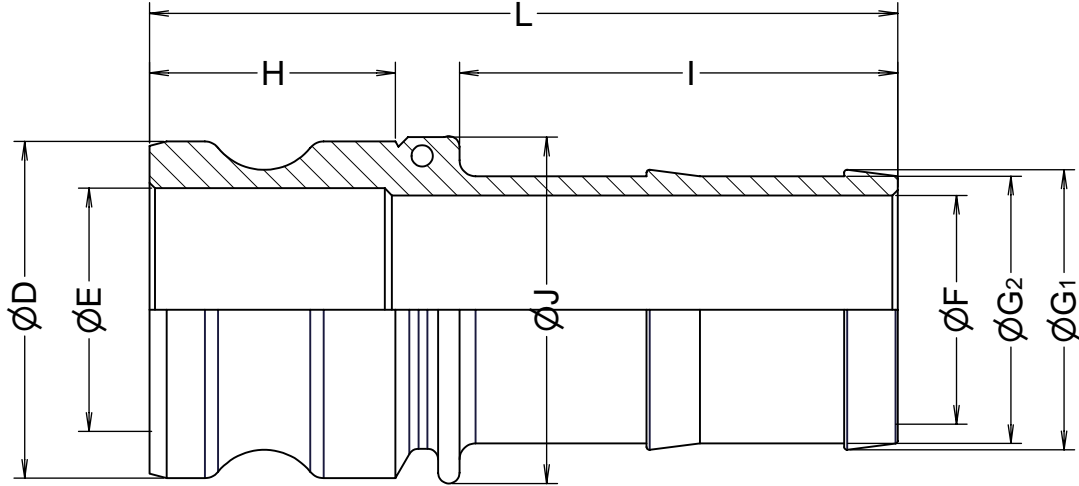

Part No.	75x50-E	75-E	100-E	125-E	150-E	200-E	250-E	300-E	400-E	
Size	mm	20x15	20	25	32	40	50	65	80	100
	inches	3/4x1/2	3/4	1	1-1/4	1-1/2	2	2-1/2	3	4
ØD	32	32	36.7	45.5	53.4	63	75.8	91.5	119.5	
ØE	21	21	23.6	28.6	36	45	55.5	73	98	
ØF	8	13.5	18.5	24	31	43	54	62	90	
ØG ₁	15	20.2	27	34	40	52.4	65	76.5	103	
ØG ₂	12	18.4	25	32	38	50	63	74	100	
ØJ	32	33	39	48	56	65	82	95	127	
H	27	28	33	40	40	46	48	49	52.5	
I	36	53	62	62	68.5	82	94	105	111	
L	66.5	91	105	113.5	121	139	156	170	179	
Weight(kg)	0.04	0.06	0.1	0.17	0.21	0.3	0.49	0.7	1.01	

Units:mm

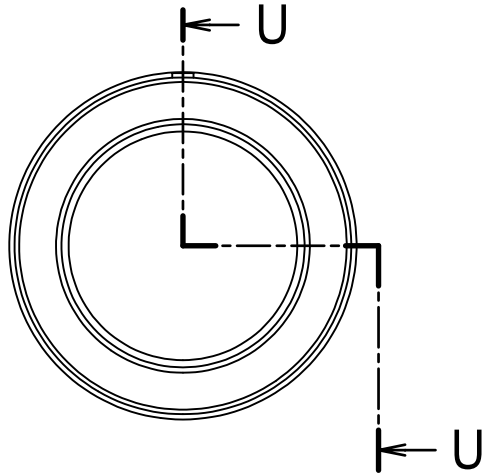

Section U-U

1	ボディ	AC4D-T6	1	
ITEM	PART NAME	MATERIAL	Q'TY	REMARKS
CUSTOMER		TITLE		
		MAX-LOK		
		MAX-Eホースシャンクアダプター		
DATE	SCALE	DRAW	APPR	
Feb.16'06	none	ToMo		
DWG No.				
MAX-E-01AL-AC4D		3		
		 FULLNESS JAPAN CORPORATION.		